

**GaAs SPDT Switch
DC - 6.0 GHz**

**MASW6010G
V5**

Features

- Low Insertion Loss: 0.5 dB Typical @ 4 GHz
- Fast Switching Speed: 4 nS Typical
- Ultra Low DC Power Consumption
- Integral Static Protection

Description

M/A-COM's MASW6010G is an SPDT GaAs MESFET MMIC. This part combines small size, low insertion loss and power consumption with high isolation. Ideal for many applications and module use. It will function well for designs below 6 GHz.

This die includes full passivation for performance and reliability.

Pad Layout

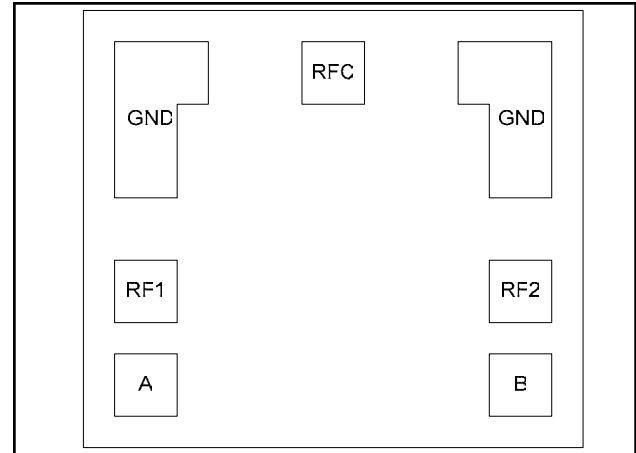

Ordering Information¹

| Part Number | Package |
|-------------|---------|
| MASW6010G | Die |

1. Die quantity varies.

Bond Pad Dimensions

| Bond Pad | Dimension Inches (mm) |
|------------|--|
| RFC | 0.004 x 0.004 (0.100 x 0.100) |
| RF2, RF3 | 0.004 x 0.004 (0.100 x 0.100) |
| A, B | 0.004 x 0.004 (0.100 x 0.100) |
| GND1, GND2 | 0.012 x 0.004 (0.300 x 0.100) |
| DIE Size | 0.031 x 0.031 x 0.010 (0.80 x 0.80 x 0.25) |

Absolute Maximum Ratings²

| Parameter | Absolute Maximum |
|-----------------------|---------------------------|
| Control Voltage (A/B) | -8.5 VDC |
| Input RF Power | +42 dBm (500 MHz - 6 GHz) |
| Operating Temperature | +175°C |
| Storage Temperature | -65°C to +175°C |

2. Exceeding any one or combination of these limits may cause permanent damage to this device.

Schematic

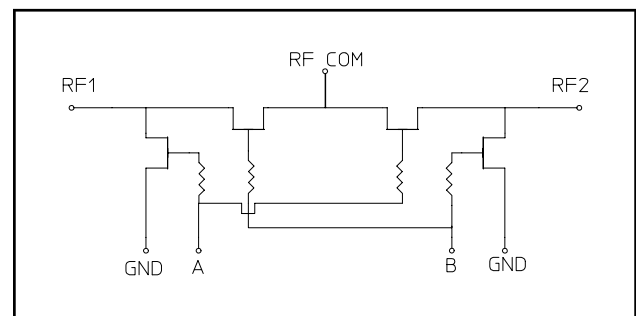

**GaAs SPDT Switch
DC - 6.0 GHz**

**MASW6010G
V5**

Electrical Specifications^{3,4}: $T_A = 25^\circ\text{C}$, $Z_0 = 50\Omega$

| Parameter | Test Conditions | Units | Min. | Typ. | Max. |
|--|---|---------------|------|------|-------|
| Insertion Loss | DC - 1.0 GHz | dB | — | — | 0.6 |
| | DC - 2.0 GHz | dB | — | — | 0.8 |
| | DC - 6.0 GHz | dB | — | — | 1.4 |
| Isolation | DC - 1.0 GHz | dB | 45 | — | — |
| | DC - 2.0 GHz | dB | 38 | — | — |
| | DC - 6.0 GHz | dB | 22 | — | — |
| VSWR | DC - 1.0 GHz | Ratio | — | — | 1.1:1 |
| | DC - 2.0 GHz | Ratio | — | — | 1.2:1 |
| | DC - 6.0 GHz | Ratio | — | — | 1.9:1 |
| Trise, Tfall | 10% to 90% RF and 90% to 10% RF | nS | — | 2 | — |
| Ton, Toff | 50% control to 90% RF, and 50% control to 10% RF | nS | — | 4 | — |
| Transients | In-Band | mV | — | 10 | — |
| Input P1dB | Above 500 MHz, 0 to -5 V | dBm | — | +27 | — |
| | 100 MHz, 0 to -5 V | dBm | — | +21 | — |
| | Above 500 MHz, 0 to -8 V | dBm | — | +33 | — |
| | 100 MHz, 0 to -8 V | dBm | — | +26 | — |
| IP2 | Two Tone, +5 dBm/Tone, 5 MHz Spacing Above 500 MHz | dBm | — | +68 | — |
| | 100 MHz | dBm | — | +62 | — |
| IIP3 | Two Tone, +5 dBm/Tone, 5 MHz Spacing Above 500 MHz | dBm | — | +46 | — |
| | 100 MHz | dBm | — | +40 | — |
| Control Voltage (Complementary Logic) | V_{IN} Low, 0 to -0.2 V | μA | — | — | 20 |
| | V_{IN} High, -5 V | μA | — | — | 50 |
| | V_{IN} High, -8 V | μA | — | — | 300 |

3. All specifications apply with 50-ohm impedance connected to all RF ports, 0 and -8 VDC control voltages.

4. Loss changes 0.0025 dB/°C (From -55°C to +85°C).

Handling Procedures

Please observe the following precautions to avoid damage:

Static Sensitivity

Gallium Arsenide Integrated Circuits are sensitive to electrostatic discharge (ESD) and can be damaged by static electricity. Proper ESD control techniques should be used when handling these devices.

Truth Table⁵

| Control Inputs | | Condition of Switch RF Common to each RF Port | |
|----------------|--------------|--|-----|
| A | B | RF1 | RF2 |
| V_{IN} Hi | V_{IN} Low | On | Off |
| V_{IN} Low | V_{IN} Hi | Off | On |

5. V_{IN} Low = 0 to -0.2 V, V_{IN} High = -5 to -8 V.

Typical Performance Curves

Insertion Loss

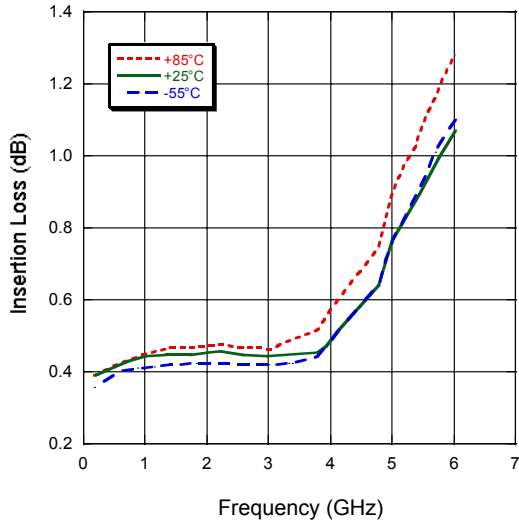

Isolation

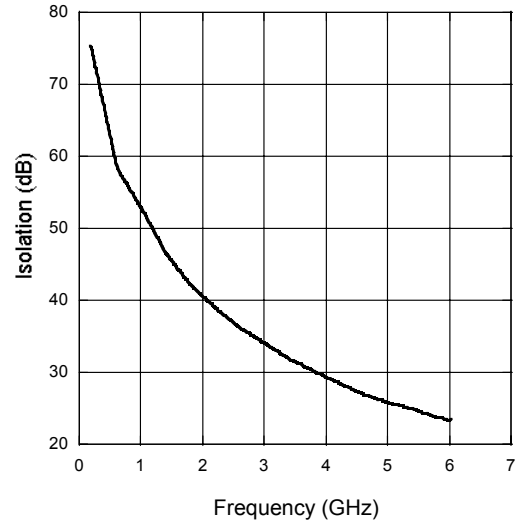

VSWR

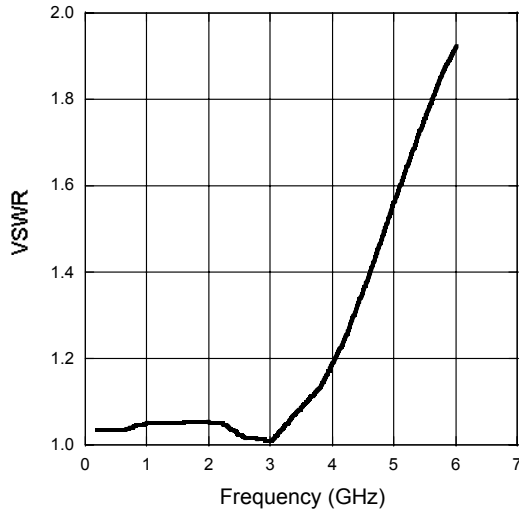

**GaAs SPDT Switch
DC - 6.0 GHz**

**MASW6010G
V5**

Handling Procedures

Permanent damage to the MASW6010G may occur if the following precautions are not adhered to:

- A. Cleanliness - The MASW6010G should be handled in a clean environment. DO NOT attempt to clean assembly after the MASW6010G is installed.
- B. Static Sensitivity - All die handling equipment and personnel should be DC grounded.
- C. Transients - Avoid instrument and power supply transients while bias is connected to the MASW6010G. Use shielded signal and bias cables to minimize inductive pick-up.
- D. Bias - Apply voltage to either control port A/B or only when the other is grounded. Neither port should be allowed to "float".
- E. General Handling - It is recommended that the MASW6010G chip be handled along the long side of the die with a sharp pair of bent tweezers. DO NOT touch the surface of the chip with fingers or tweezers.

Mounting

The MASW6010G is back-metallized with Pd/Ni/Au (100/1,000/30,000Å) metallization. It can be die-mounted using Au/Sn eutectic preforms or a thermally conductive epoxy. The package surface should be clean and flat before attachment.

Eutectic Die Attach:

- A. An 80/20 Au/Sn preform is recommended with a work surface temperature of approximately 255°C and a tool temperature of 265°C. When hot 90/10 nitrogen/hydrogen gas is applied, solder temperature should be approximately 290°C.
- B. DO NOT expose the MASW6010G to a temperature greater than 320°C for more than 20 seconds. No more than 3 seconds of scrubbing should be required for attachment.

Epoxy Die Attach:

- A. Electrically conductive epoxy must be used.
- B. Apply a minimum amount of epoxy and place the MASW6010G into position. A thin epoxy fillet should be visible around the perimeter of the die.
- C. Cure epoxy per manufacturer's recommended schedule.

Wire Bonding

- A. Ball or wedge bond with 1.0 mil diameter pure gold wire. Thermosonic wire bonding with a nominal stage temperature of 150°C and a ball bonding force of 40 to 50 grams or wedge bonding force of 18 to 22 grams is recommended. Ultrasonic energy and time should be adjusted to the minimum levels to achieve reliable wirebonds.
- B. Wirebonds should be started on the chip and terminated on the package.